

# QUICK START GUIDE For Series P, PD, B, C, E, Roytronic A, and Excel AD

No. : 56383  
Rev. : 01  
Rev. Date : 08/2017

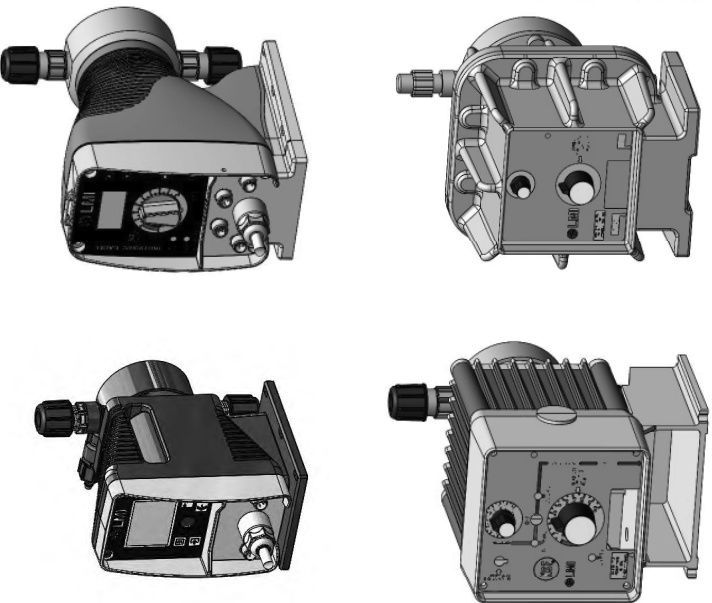

## Precautions

The following precautions should be taken when working with LMI® metering pumps. Please read this section carefully prior to installation.

### Protective Clothing

ALWAYS wear protective clothing, face shield, safety glasses and gloves when working on or near your metering pump. Additional precautions should be taken depending on the solution being pumped. Refer to SDS precautions from your solution supplier.

### Water Pre-Prime

All LMI® pumps are pre-primed with water when shipped from the factory. If your solution is not compatible with water, disassemble the Pump Head Assembly. Thoroughly dry the pump head, valves, seal rings, balls and LIQUIFRAM™ diaphragm. Reassemble head assembly tightening screws in a crisscross pattern. Refill the pump head with the solution to be pumped before priming the pump. (This will aid in priming.)

### Solution Compatibility

The evaluation performed by UL was tested with water only. LMI® pumps are tested to NSF 50 for use on hydrochloric acid (31%) and sodium hypochlorite (12.5%). These pumps are also certified to NSF / ANSI Standard 61 and 372. Please check our listings with NSF International to confirm certified chemicals and concentrations for use. E Series pumps are not certified to NSF 50, 61 or 372. Always refer to the solution supplier and the LMI® Chemical Resistance Chart for compatibility of your specific LMI® metering pump. Contact your local LMI® distributor for further information.

### Tubing Connections

Inlet and outlet tubing or pipe sizes must not be reduced. Make certain that all tubing is SECURELY ATTACHED to fittings prior to start-up. ALWAYS use LMI® supplied tubing with your pump, as the tubing is specifically designed for use with the pump fittings. It is recommended that all tubing be shielded to prevent possible injury in case of rupture or accidental damage. If tubing is exposed to sunlight, black UV resistant tubing should be installed. Check tubing frequently for cracks and replace as necessary.

### Fittings and Machine Threads

All fittings should be hand-tightened. An additional 1/8 - 1/4 turn after the fitting contacts the seal ring may be necessary to provide a leak-proof seal. Excessive over tightening or use of a pipe wrench can cause damage to the fittings, seals, or pump head. All LMI® pumps have straight screw machine threads on the head and fittings and are sealed by the seal rings or O-rings. **DO NOT use PTFE tape or pipe dope to seal threads. PTFE Tape may only be used on the 1/2" NPT thread side of the Injection Check Valve as well as stainless steel liquid end connections.**

### Plumbing

Always adhere to your local plumbing codes and requirements. Be sure installation does not constitute a cross connection. Check local plumbing codes for guidelines. LMI® is not responsible for improper installations.

### Back Pressure / Anti-Syphon Valve

If you are pumping downhill or into low or no system pressure, a back pressure / anti-syphon device such as LMI®'s Four Function Valve (4-FV) should be installed to prevent over pumping or syphoning. Contact your LMI® distributor for further information.

### Line Depressurization

To reduce the risk of chemical splash during disassembly or maintenance, all installations should be equipped with line depressurization capability. Using LMI®'s Four-Function Valve (4-FV) is one way to include this feature.

### Over Pressure Protection

To ensure safe operation of the pump it is recommended that some type of safety / pressure relief valve be installed to protect the piping and other system components from failing due to excessive pressure.

### Chemical Concentration

There is a potential for elevated chemical concentration during periods of no flow, for example, during backwash in the system. Steps, such as turning the pump OFF, should be taken during operation or installation to prevent this. See your distributor about other external control options to help mitigate this risk.

### Retightening Components

Plastic materials will typically exhibit creep characteristics when under pressure over a period of time and to insure a proper fit it may be necessary to retighten the head bolts periodically. To insure proper operation, we recommend tightening the bolts to 25 inch-pounds after the first week of operation and on a monthly basis thereafter.

### Electrical Connections

To reduce the risk of electrical shock, install only on a circuit protected by a ground-fault circuit interrupter (GFCI). The metering pump must be plugged into a grounded outlet with ratings conforming to the data on the pump control panel. The pump must be connected to a good ground. **DO NOT USE ADAPTERS!** All wiring must conform to local electrical codes. If the supply cord is damaged, it must be replaced by the manufacturer, stocking distributor or authorized repair center in order to avoid a hazard.

Do not hook a US style pump plug into a non-US (UK, Aust, NZ or Swiss) wired power system. The US style 240 VAC power system has two 110 VAC hot legs and one neutral. The European style system has one 240 VAC hot leg and a neutral. Hooking up a US pump to the European wired system will cause pump failure.

© 2017 Milton Roy, LLC.

ROYTRONIC® is a registered trademark of Milton Roy, LLC.  
FASTPRIME™ is a trademark of Milton Roy, LLC.  
AUTOPRIME™ is a trademark of Milton Roy, LLC.  
LIQUIPRO™ is a trademark of Milton Roy, LLC.  
LIQUIFRAM™ is a trademark of Milton Roy, LLC.  
MILTON ROY is a trademark of Milton Roy, LLC.

info@lmipumps.com  
www.lmipumps.com



*We are a proud member of Accudyne Industries, a leading global provider of precision-engineered, process-critical, and technologically advanced flow control systems and industrial compressors. Delivering consistently high levels of performance, we enable customers in the most important industries and harshest environments around the world to accomplish their missions.*

For complete product documentation  
please visit:

[support.lmipumps.com](http://support.lmipumps.com)

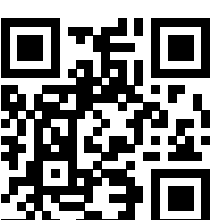

From there, you can quickly access:

- The latest product manuals and technical documentation
- Sales brochures and promotional material
- Certification and engineering files

Search by keyword, product series, or model number

Filter by result type, product, and language

Download to your computer, tablet, or phone for offline access

Flip for quick start guide:



## Pump Mounting

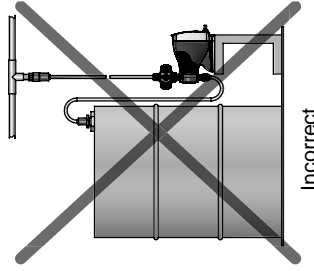

Incorrect

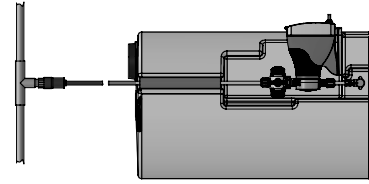

Flooded Suction with LMI Tank

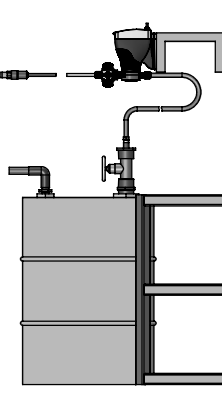

Alternative Flooded Suction

## Foot Valve / Suction Tubing Installation

1. Attach the foot valve to one end of the suction tubing.
2. Slide the ceramic weight over the tubing end until it contacts the top of the foot valve coupling nut.
3. Place foot valve and tubing into the solution tank. Check that the foot valve is vertical and approximately 2 inches (50mm) from the bottom of the tank or drum. Connect the other end of the tubing to the suction side of the pump head.

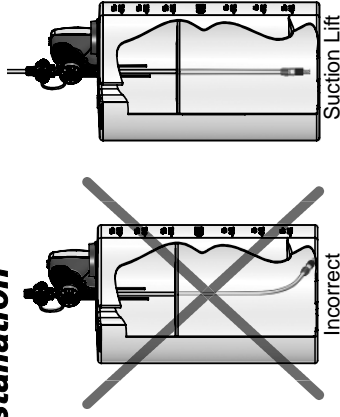

**CAUTION** When pumping downhill or into a low or no pressure system, a back pressure / anti-siphon device should be installed to prevent overpumping or syphoning.

**Note:** NEVER position pump head and fittings horizontally.

### 1. Flooded Suction

The pump is mounted at the base of the storage tank. Recommended for very low outputs, solutions that gasify and high viscosity solutions.

### 2. Suction Lift

When suction lift is less than 5ft (1.5m) for solutions having a specific gravity of water. For denser solutions, consult distributor. Your LMI® metering pump must be mounted so that the suction and discharge valves are vertical.

#### a. Wall Bracket Mount

The pump may be mounted using an LMI® Wall Mount Bracket Assembly (part no. 34643) directly above the solution tank. A pump mounted in this manner allows for easy changing of solution tanks or drums.

#### b. Tank Mount

The pump may be mounted on a molded tank provided there is a recess to keep the pump stationary. LMI®10-gallon tank (part no. 27421), 35-gallon tank (part no. 27400), and 50-gallon tank (part no. 26350) have molded recesses for pump mounting.

#### c. Shelf Mount

The pump may be mounted on a shelf (customer supplied) maintaining a suction lift of less than 5ft. (1.5m). An LMI® mounting kit (part number 10461) is available for securing the pump to a shelf.

## Four-Function Valve Installation

1. To mount to a pump, remove the discharge fitting from the pump (if present) leaving the cartridges in the pump head. Position the 4-FV coupling nut on the pump head over cartridges with threads up, and insert 4-FV fitting and thread into pump head over cartridges. Tighten the fitting to 40in-lbs using a 13/16" or 20mm socket. Insert the large opening on the 4-FV into the 4-FV coupling nut and hand tighten. You can position the valve to have the pressure relief port in any convenient location by tightening the 4-FV coupling nut with the pressure relief port positioned 90° CCW from desired location, then holding the nut stationary while turning the valve the final 90° to desired position.

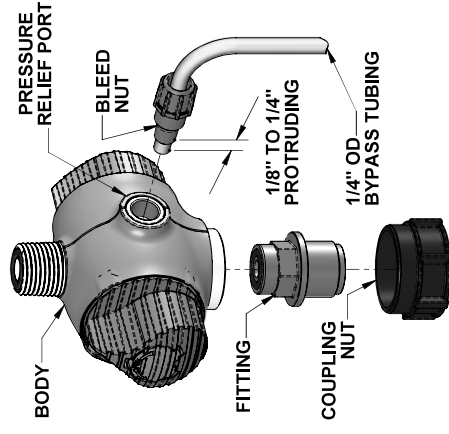

2. Connect 1/4" tubing to the pressure relief port and route to supply container.

3. Connect discharge line using LMI® tubing connection system or 1/2" pipe thread. The 4-FV is designed for double-ball checks. A second valve cartridge is required when mounting a 4-FV to an existing pump with a 300, 400, 800 or 900 series liquid end.

## Tubing Connections

1. Insert tubing through Coupling Nut—Tubing should enter the smaller end of the Coupling Nut first, orienting the larger opening of the Coupling Nut toward the tubing end.

- a. For 1/4" OD tubing: Position the Female Ferrule so that 1/4" to 3/8" (5-10 mm) of tubing protrudes from the Female Ferrule. Orient the raised collar of the Ferrule toward the Coupling Nut.

- b. For 3/8" or 1/2" OD tubing: Position a Female Ferrule about 1 inch (25mm) from end of tubing. Orient the raised collar of the Female Ferrule toward the Coupling Nut. Then, insert the Male Ferrule onto the end of the tube, pushing the tube into the bottom of the groove in the Male Ferrule. Then slide the Female Ferrule down the tubing and with your fingers, press tightly into the Male Ferrule.

2. Firmly hand tighten the Coupling Nut onto the fitting.

**Note:** Tightening with pliers may cause the ferrules to break.

DO NOT USE PLIERS OR PIPE WRENCH ON COUPLING NUTS OR FITTINGS.

DO NOT REUSE FERRULES—USE ONLY NEW FERRULES.

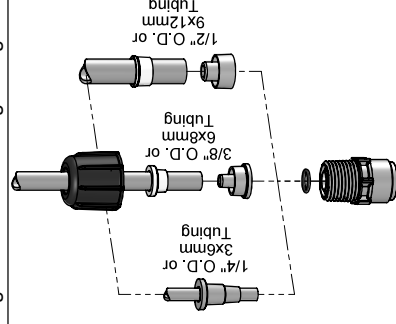

## Start-up / Priming

**CAUTION** READ THIS ENTIRE SECTION COMPLETELY BEFORE PROCEEDING.

When all precautionary steps have been taken, the pump is mounted, and the tubing is securely attached, you may now start priming the pump.

**Note:** The pump is normally self-priming if suction lift is 5ft. (1.5m) or less and the steps below are followed.  
**Note:** Pumps are shipped from the factory with water in the pump head to aid in priming.

### For Autoprime™ Liquid Ends

1. Plug in or switch ON the pump.
2. While the pump is running, set the speed and stroke knob at 100%.
3. The suction tubing should begin to fill with solution from the tank as the AUTOPRIME™ valve purges air from the pump head.
4. Once the solution begins to exit the pump head through both the discharge valve and the AUTOPRIME™ valve, **SHUT THE PUMP OFF.**
5. The pump is now primed.
6. Proceed to output adjustment.

### For LiquiPro™ or Legacy LMI Liquid Ends

#### WITHOUT Multi-Function Valve

1. Plug in or switch ON the pump.
2. While the pump is running, set the speed and stroke knob at 100%.
3. The suction tubing should begin to fill with solution from the tank.
4. Once the solution begins to exit the pump head on the discharge side, **SHUT THE PUMP OFF.** (If pump is not equipped with an ON / OFF switch, disconnect the power cord).
5. The pump is now primed.
6. Proceed to output adjustment.

**Note:** If the pump does not self-prime, remove the fitting on the discharge side of the pump head. Remove the ball and pour water or solution into the port until the head is filled. Replace valve, then follow start up / priming steps.

#### Output Adjustment

Once the pump has been primed, an appropriate output adjustment **MUST** be made. Pump output should be calculated and adjustments made accordingly.

#### Pump Output:

**MAX PUMP OUTPUT x % SPEED x % STROKE** Divide by 24 (hours in one day) to calculate in gallons per hour.

**Note:** If pump is not equipped with speed adjustment, calculate by *Max Pump Output x % Stroke only.*

## Liquid End Tubing Installation

### Autoprime™ Liquid End

When installing a pump equipped with an AUTOPRIME™ Liquid End, connect the 1/2" OD Polyethylene tubing to the top vertical fitting, and route this line back to the supply tank. To ensure priming, this tubing should not be submerged in the solution. The horizontal fitting is the discharge, and the bottom vertical fitting is the suction.

### Fastprime™ Liquid End

The FASTPRIME™ Head is equipped with a valve that allows for opening the head to atmospheric pressure. When installing a pump equipped with a FASTPRIME™ Head connect the 3/8" outer diameter clear vinyl tubing provided with the pump to the barbed nozzle. Route the vinyl return line back to the solution tank. This tubing must not be submerged in the solution.

## Injection Check Valve And Discharge Tubing Installation

### 1. Installing Injection Check Valve

- a. The Injection Check Valve prevents back flow from a treated line. Install the injection check valve at the location where chemical is being injected into the system.
- b. Any size Female NPT fitting or pipe tee with a reducing bushing to 1/2" Female NPT will accept the injection check valve. PTFE tape should only be used on threads that are connected with pipes.
- c. When installing the Injection Check Valve, be sure to position it so that the valve enters the bottom of your pipe in a vertical position. Variations 40° left and right are acceptable.

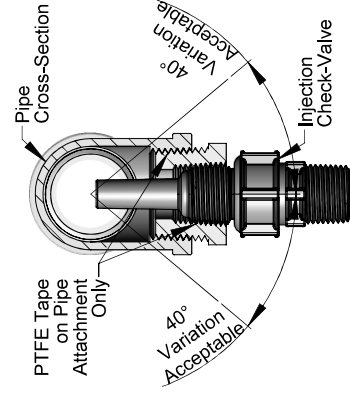

Install Injection Valve Vertically

### 2. Connecting Discharge Tubing

**Note:** Cut tubing to length needed for discharge line. a. Route tubing from the injection check valve to the metering pump, making sure it does not touch hot or sharp surfaces, or is bent so sharply that it kinks.

## Calibration

The pump should be calibrated to adjust speed and stroke for your actual desired output.

**Note:** For pumps equipped with built in calibration, see respective series manual.

1. Be sure the pump is primed and discharge tubing, and Injection Check Valve are installed as they would be in normal service.
2. Place the Foot Valve in a graduated container with a volume of 1000 ml or more.
3. Plug in and switch pump to Internal Mode. Pump until all the air is exhausted from the suction line and head.
4. Turn the pump OFF. Refill graduated container to a level starting point.
5. Using a stopwatch or timer, turn pump ON for a measured amount of time (50 pump strokes minimum). The longer the time period, the more confident you can be of the results. Count the number of strokes during the calibration period when making comparisons.
6. Turn the pump OFF. Note the time elapsed in relation to volume displaced in the graduate. Now, calculate the output in the time unit you choose (minutes, hours, days etc.).
7. If the output is too low or too great, adjust speed and / or stroke, estimating required correction and repeat steps 1-7.

